

XIV) EXPLODED VIEWS

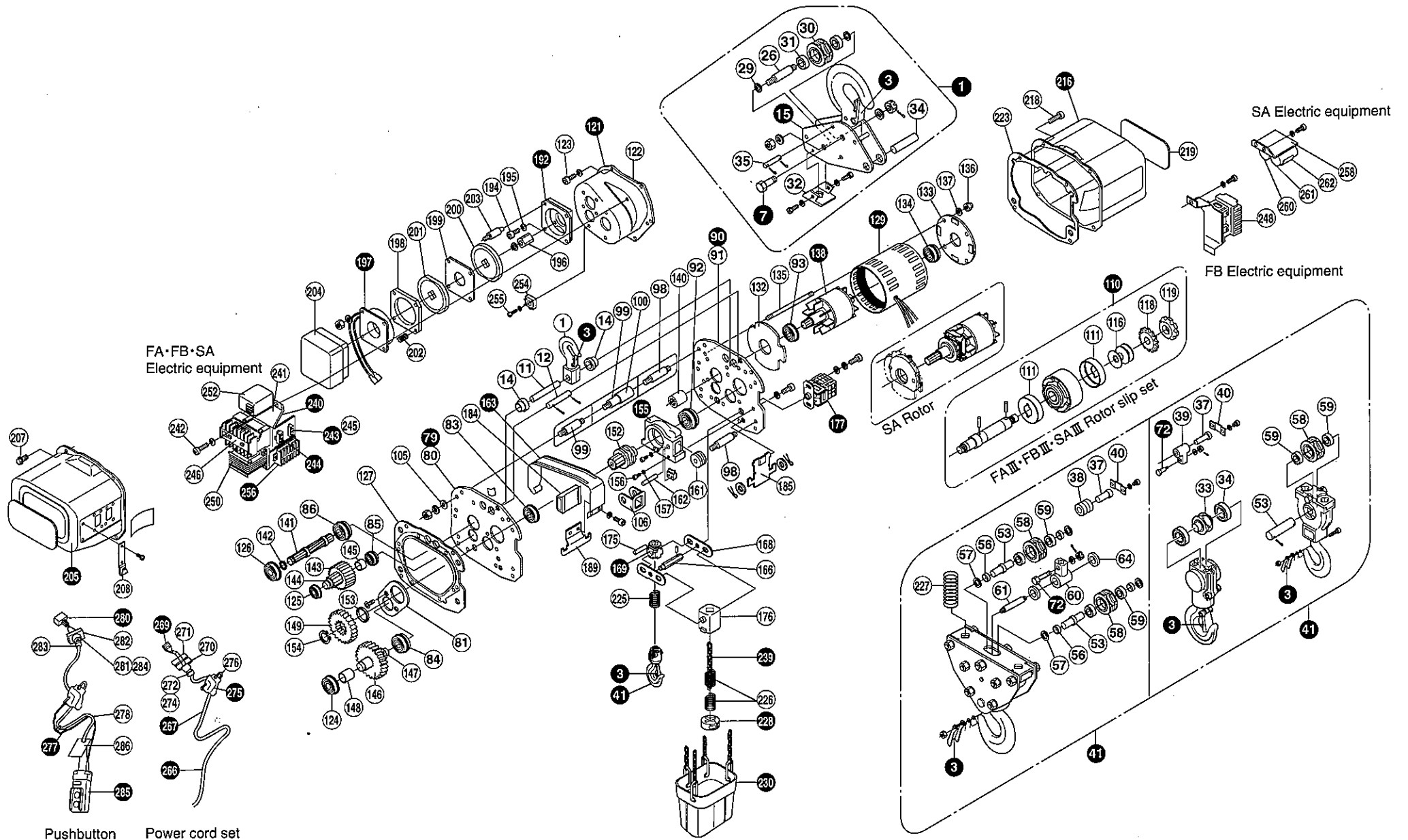

- 1 Top hook set
- 3 Safety latch set
- 7 Connecting pin set
- 11 Top hook pin
- 12 Top hook stopper pin
- 14 Bush
- 15 Top hanger fitting set
- 26 Idle wheel pin
- 29 Washer for idle wheel axle
- 30 Idle wheel
- 31 Ball bearing
- 32 Switch spring guide
- 34 Top hanger fitting pin
- 35 Stopper pin (top)
- 37 Multifall pin
- 38 Chain roller
- 39 Chain hanger fitting
- 40 Pinholder for multi-falls
- 41 Bottom hook set
- 53 Idle wheel pin
- 56 Washer for idle wheel
- 57 Collar for idle wheel
- 58 Idle wheel
- 59 Ball bearing
- 60 Chain hanger fitting
- 61 Chain hanger fitting pin
- 64 Chain hanger fitting collar
- 72 Top hook stopper bolt set
- 79 Gear side plate set
- 80 Gear side plate
- 81 Flange B
- 83 Ball bearing
- 84 Ball bearing
- 85 Ball bearing
- 86 Ball bearing
- 90 Motorside plate set
- 91 Motorside plate
- 92 Ball bearing
- 93 Ball bearing
- 98 Stay bolt (A)
- 99 Stay bolt (B)
- 100 Stay pipe
- 105 Washer
- 106 Cabtyre holder
- 110 Rotor slip set
- 111 Disk hub
- 116 Plate spring
- 118 Lock washer
- 119 Adjust nut
- 121 Gear case set
- 122 Gear case
- 123 Hex. bolt w/ cross hole
- 124 Ball bearing
- 125 Ball bearing
- 126 Ball bearing
- 127 Gear case packing
- 129 Motor set
- 132 Positioning plate
- 133 Motor bracket
- 134 Ball bearing
- 135 Motor stay bolt
- 136 Hex. cap nut
- 137 Spring washer
- 138 Rotor assy
- 140 Motorshaft joint
- 141 1st gear
- 142 C-clip
- 143 2nd gear
- 144 3rd gear
- 145 3rd gear collar
- 146 4th gear
- 147 5th gear
- 148 5th gear collar
- 149 6th gear
- 152 Load sheave set
- 153 Sheave collar
- 154 C-clip
- 155 Chain guide set
- 156 Bolt w/ hex. hole
- 157 Spring washer
- 161 Roller
- 162 Roller pin
- 163 Sheave cover set
- 166 Operating element
(hex. shaft)
- 168 Operating plate
- 169 Operating element A set
- 175 Operating element A stopper
- 176 Operating element B
- 177 Limit switch set
- 184 Lead cord protecting rubber
- 185 Chain bucket fitting
- 189 Chain bucket hanger fitting
- 192 Magnetic brake holder set
- 194 Bolt w/ hex. hole
- 195 Spring washer
- 196 Square hub
- 197 Magnetic brake set
- 198 Armature (A)
- 199 Armature (B)
- 200 Brake lining (A)
- 201 Brake lining (B)
- 202 Brake spring
- 203 Brake stay bolt
- 204 Brake cover
- 205 Electric equipment set
- 207 Hex. bolt w/ cross hole
- 208 Pushbutton hanger fitting
- 216 Motorside case set
- 218 Hex. bolt w/ cross hole
- 219 Name plate
- 223 Case packing
- 225 Switch spring (A)
- 226 Switch spring (B)
- 227 Switch spring (C)
- 228 Chain stopper set
- 230 Chain bucket set
- 239 Load chain complete
- 240 Electric equipment set
- 241 Electric equipment holder
- 242 Hex. bolt w/ cross hole
- 243 Housing socket set (mains side)
- 244 Housing socket set
(pushbutton side)
- 245 Screw w/ cross hole
- 246 Electromagnetic contactor
- 248 Electromagnetic contactor
- 250 Transformer
- 252 Anti-negative phase device
- 254 Rectifier
- 255 Resin bolt
- 256 6P-terminal block set
- 258 Condenser mount (A)
- 260 Starting condenser
- 261 Run condenser
- 262 Condenser mount (B)
- 266 Power cord set
- 267 Power cord
- 269 Housing plug set
- 270 Connector case
- 271 Connector case packing
- 272 SC lock
- 274 Screw w/ cross hole
- 275 Cord holding fixture set
- 276 Shackle
- 277 Pushbutton switch set
- 278 Pushbutton cable set
- 280 Housing plug set
- 281 Connector case
- 282 Connector case packing
- 283 SC lock
- 284 Screw w/ cross hole
- 285 Pushbutton set
- 286 Warning label